

Antecedents and consequences of corporate reputation from a bi-stakeholder perspective in Turkish banking sector*

Hülya Gündüz Çekmecelioğlu, Gönül Kaya Özbağ, Ayşe Günsel, Neslihan Şevik**

Abstract

This paper examines the effects of corporate identity strength (CIS) and corporate reputation (CoR) on the performance of Turkish banks. We suggest that CIS is related to firm performance (FP). In addition, CoR is proposed as an important variable that has positive impacts on both organizational identification (OI) and FP. Presumed relationships are tested based on data obtained from 54 banks registered in the Turkey Banking System and Participation Banks Association of Turkey by using SmartPLS 3.0. The findings show that CIS is positively associated with CoR while they provide no empirical evidence in support of a direct relationship between CIS and OI, or between CIS and any of the other performance variables. Moreover, the results also provide empirical evidence regarding a positive relationship between CoR and FP in terms of self-reported and objective measures (AU= asset utilization, and ROA: return on assets). Besides, the findings support the mediation role of CoR between CIS and self reported firm performance. By highlighting the antecedent role of CIS on CoR and firm performance in the banking industry from a bi-stakeholder perspective, this study offers a framework for researchers and managers to visualize and understand the relationships between corporate-level constructs and individual and firm-level outputs, thus enhancing the movement of the Social Identity Theory in OB literature.

Keywords: Corporate identity strength, corporate reputation, identification, firm performance
JEL Codes: G21, L14.

Introduction

Organizational researchers view CoR as a social identity and depict it as a significant and intangible resource that can considerably contribute to an organization's performance, even its survival (Hall, 1993; Nguyen & Leblanc, 2001). It

* Received: 15.06.2021, accepted: 20.06.2022, 2 revisions.

- ** *Hülya Gündüz Çekmecelioğlu*, PhD, Professor of Management and Organization, University of Kocaeli, Faculty of Business Administration, Department of Business Administration. Email: hulyacekmecelioglu@gmail.com. Main research interests: Creativity, innovation, organizational commitment, leadership, empowerment, work environment.
Gönül Kaya Özbağ, PhD, Professor of Management and Organization, University of Kocaeli, Faculty of Maritime, Department of Maritime Business Management. Email: gonulozbag@gmail.com. Main research interests: Innovation, organizational climate, corporate social responsibility, leadership, organizational ethics, corporate reputation.
Ayşe Günsel, PhD, Professor of Management and Organization, University of Kocaeli, Faculty of Business Administration, Department of Business Administration. Email: agnsel@gmail.com. Main research interests: Technology and innovation management, team management.
Neslihan Şevik, PhD, Assistant Professor (Corresponding author), University of Kocaeli, Gazanfer Bilge Vocational School, Department of Office Services and Secretarial. Email: neslihanakman@hotmail.com. Main research interests: Corporate reputation, corporate identity, organizational identification, organizational culture.

requires a long time to build and is rare, hard to imitate, or substitute (Barney, 2000; Deephouse, 2000; Roberts & Dowling, 2002). CoR enables organizations to exploit opportunities and minimize threats, and therefore provide several positive outcomes, including company strength, stakeholders' loyalty, and financial stability. However, sustainable CoR management requires coherence and consistency with corporate identity (CI). A contrary situation means a negative CoR that results in failures, crises, and losses for the organization (Radomir et al., 2014:221).

At this point, it will be beneficial to explain the difference between CI and CIS. The former is defined as the underlying core or unique character of the firm (Barnett et al., 2006) whereas the latter indicates that these characteristics that differentiate the organization are widely shared and deeply held by organizational members (Kreiner & Ashforth, 2004). If CI is weak, it can hinder the organization because of the likelihood of creating confusion among external stakeholders and a potential danger for lack of trust and lack of value congruence (Hansen et al., 2011; Haski-Leventhal et al., 2017). From this point, stakeholders' attitudes are of critical importance to understand to what extent CIS or CoR management is favorable. Based on this assumption, primary purpose of this study is to explore the relationships between CIS and reputation, which are expected to impact organizational members' identification and FP.

Since a corporate entity is a human organization linked to an external environment (Olins, 1995), the behavior and identification of the staff have a significant impact on the impressions formed by members of external groups, such as customers, competitors, suppliers, investors, and media commentators (Bromley, 2000). Especially for service firms, customers often perceive employees as the service itself, the brand, or even the organization. Thus employees are assumed to be key drivers in building CoR (Elsbach & Glynn, 1996; Furman, 2010). For that reason, it is even more significant for organizational members to have a perception of CIS which can be translated into OI and so they can easily interact with customers as corporate brand ambassadors (Dutton et al., 1994). On the other hand, scholars also found that OI is also sensitive to organizational members' beliefs about how different stakeholders view the organization (e.g., Hatch & Schultz, 2000). If there is any inconsistency between the CIS and external image, organizational members may find it challenging to identify. Such evaluations by organizational members relating to CIS and CoR may lead to feelings and emotions of connectedness, belonging (i.e., organizational identification) or separation, dissociation (i.e., organizational disidentification).

Social identity theorists posit that an individual's social identity is essential in the formation of the self-concept. It describes social identity as the individual's knowledge that they belong to certain social categories (e.g., groups, organizations), a belonging that also holds some emotional significance. According

to this view, people form social identities based upon social categories, and these in turn influence and affect behaviour (Tajfel & Turner, 1986; Abrams, 1996). Therefore, this study focuses on dis-identification which is a distinctive emotional state that does not attract as much attention as OI, and investigates the impact of CIS on both OD and OI. We acknowledge a subtle complexity in the relationship between identification and disidentification: at first glance they seem to represent a bipolar, unidimensional variable. However, it is important to note that disidentification is not merely the opposite of identification. It is a separate variable and unique psychological situation so how this situation arises is worth examining as how individuals disidentify themselves from the organization still remains unclear, with under-developed theories and inadequate studies. As a matter of fact, this research also adds new insights into the OB literature regarding the reflections of CIS on OI, and specifically on OD (Riketta, 2005; Chang et al., 2013; Podnar & Golop, 2015:216).

Different from CIS, CoR in our research model expresses a general perception of a company shared by its bi-stakeholders (Koporcic & Halinen, 2018). It is an expression that covers the impressions of both internal and external stakeholders about the company. Recent studies have proved that views of organizational members and customers on reputation are interrelated and interlinked (Fombrun, 1996; Gioia et al., 2000; Hatch & Schultz, 2001) as customer service, networking, and corporate communications have increased the visibility of insiders to outsiders (Hatch & Schultz, 1997). Rather than relying on purposefully devised marketing communication messages from top management, consumers are more likely to believe information relayed through employees. Besides, by the innovative use of new digital technologies, employees increasingly communicate with other stakeholders and initiate dialogues through social media that are often perceived to be more reliable and trustworthy than intentionally created messages (Kim & Rhee, 2011; Men, 2012). Therefore, employee-customer interactions will guide and maintain CR only if employees are closely identified with their firm, which implies a strong belief in firm values and culture (Fuller et. al., 2006; Shamma & Hassan, 2009). Significant gaps between the internal and external stakeholders' views regarding the organization have been associated with performance failures (Dowling, 1994). This interaction becomes even more impressive in the banking sector because, unlike other businesses, banks have a direct interaction with customers, and thus the quality of service can be felt immediately on the spot (Svensson, 2006; Siano et. al., 2007). Therefore in this study, reputation is evaluated via perceptions of customers (external stakeholders) and CIS via perceptions of employees (internal stakeholders), which enables authors to examine the interactive relationship between internal and external stakeholders.

When we examine the Turkish banking sector, where this research was carried out, we see that the sector has undergone very important changes and has

emerged stronger from these changes. It has a history of approximately 200 years and it is a sector that led Turkey's transition to open growth model in the 1980s. The Turkish banking sector shrank around 6% due to the economic crisis of the Turkish economy in November 2000 and February 2001 and therefore decreased the number of branches and employees (Sumer, 2013). However, on April 14, 2001, with the support of the World Bank, the Transition to a Strong Economy Program was put into effect and the financial sector was restructured accordingly. With the legal regulations, the Turkish Banking Sector has played an important role in increasing Turkey's competitiveness in the international arena (Sümer, 2016:491). At this point, the Turkish banking sector has a very important place in the Turkish economy with its strong financial structure, autonomous supreme boards, audit mechanisms, talented workforce and advanced technology, and it is a sector that has banks with high corporate reputation in the society.

Service sector in general and banking sector in particular traditionally rely more on their CR as the intangible nature of services makes it hard to differentiate themselves and to position their offerings at the top of consumers' preference list. It is, therefore, well recognized that the success of a bank depends significantly on the favorable reputation that the customers holds about it. The banking service sector in Turkey, which is examined in this study, is not an exception to the the competitive conditions of service sector firms in other countries. After the global crisis, the financial problems experienced around the world led to new regulations to keep the sector under control in the light of banking products, and forced Turkish banks to keep up with the changing conditions in the rest of the world and compete with domestic and foreign banks that had just entered the sector to maintain their competitiveness. In this environment, having positive reputation that creates loyal customers has become a key success factor for Turkish banks.

Another significant contribution of this study is that it examines the effects of CoR on FP with both subjective (i.e., quantitative and qualitative values) and objective (i.e., ROA and ROE values) measures that were mostly neglected in previous studies. Consequently, this study contributes to the literature in many ways. First, it fills the gap in previous research by linking CIS, CoR, OI, OD and FP. Second, this study is the first to assess CoR through the eyes of customers and CIS through the eyes of employees, and thus will provide evidence for the interaction between insiders and outsiders that is assumed but not supported by empirical data in the literature. Last but not least, all banks in Turkey have been reached in the data collection process that supports the generalizability of research results. The rest of the paper is structured as follows: In the theoretical background and hypotheses development parts respectively, the relationships among CIS and CoR; CIS CoR, and OI & OD; CIS, CoR, and FP are analyzed and also the hypotheses of the study were developed in the light of previous

studies. Methodology part presents our data and describes the construction of variables used in the empirical analysis. Then, empirical results are discussed in the discussion part. After discussing the theoretical and managerial implications and how this research adds value to the existing Social Identity Theory structure in the OD literature, the article concludes by mentioning the limitations of some research.

1. Theoretical background and hypotheses development

1.1 *Corporate identity strength and corporate reputation*

CI is concerned with what the organization is and what it aspires to be and captures the essential features believed to be central, enduring, and distinctive of an organization (Albert & Whetten, 1985). It is different from the concept of CIS as the latter is the extent to which individual members believe that the organization has a common and unique identity. It reflects a strong common spirit of comradeship that leads members to work in unity by a common sense of purpose, vision and mission (Boehm et al., 2015). It tends to give clear meaning and unique vision (who we are), which allows them to decide whether the identity of the organization matches their needs, values and desires (Munawir et al, 2019). Indeed, CI is a valuable asset that is created by the conscious efforts of the executives relating to the distinct characteristics of the organization (their mission, core values, culture, key products etc.) whereas CIS indicates that these efforts are successful and that the employees have a sense of pride in the corporation's values, goals and missions.

We propose that CIS has an impact on FP through two main channels; OI and CoR. First, scholars seem to agree that CIS is one of the key antecedents of OI (e.g Cole & Bruch, 2006) and thus it may reveal its impact on FP by influencing the organization's employee identification. Employees who are strongly identified with their organizations seem more likely to exhibit greater organizational loyalty, better work performance and innovative behaviour all of which are related with high FP. OI also enhances the perception of oneness, belongingness and a “we-feeling” within organizations (Caza et al., 2018) which in turn may decrease disagreements and conflicts among organization members (Boehm et al., 2015) with positive implications for FP. Consequently, highly identified employees are more collaborative and supportive to each other, engaged in extra-role behaviors and focused on serving the best interests of the organization (Avanzi et al., 2015).

CIS may further contribute to FP by affecting CoR. It not only facilitates the identification of employees with the organization, but also facilitates external stakeholders to develop a positive attitude towards the organization. The stronger the CI, the more likely its external projection is to be authentic, persuasive, reassuring and powerful (Boehm et al., 2015). As understood from concep-

tual relationships, reputation is a specific type of feedback that an organization receives from its stakeholders regarding the credibility of the corporate's identity claims. This assumption is in line with the marketing literature, which proposes that organizational members need to share core values and missions in order to mirror a coherent picture of their organization when communicating with external customers. Indeed, in corporate branding literature, CI and CoR are seen to affect one another (Cornelissen et al., 2012).

Both concepts are strategic tools used to achieve organizational success and provide many benefits for organizations. However, as far as the authors knowledge, there is no empirical study that directly explores the effects of CIS on CoR. Accordingly, we propose;

H1: CIS will have a positive impact on CoR.

1.2 Corporate identity strenght, corporate reputation, and organizational identification & disidentification

OI shows the extent to which the individual identifies him or herself with his or her organization and represents the employee's perception of "being one" with the organization. It is a psychological condition that underlines the link between the individual and the organization (Edwards, 2005). OI can be traced back to Social Identity Theory (SIT), which suggests that individuals' identities, drawn from group membership, are the key influencers of their self-concepts. Accordingly, employees internalize the organization's norms and values and perceive organizational membership as a part of their personalities. The association of SIT with OI is based on the studies of Ashforth and Mael (1989) and Dutton et al. (1994). One of the most striking discourses of the theory is the assumption that the individuals tend to identify with their organizations if the organization has a favourable CoR (Mael & Ashforth, 1992; Gotsi & Wilson, 2001).

Research at the organizational level shows that CoR is closely related to both an employee's identification and disidentification (Gotsi & Wilson, 2001). Thus, one of the self-assessment criteria of employees is how the corporation they work for is perceived outside. For individuals, working in organizations with high CoR means having a higher status and being respected compared to others. In the case of a high CoR, the individual starts to see himself or herself as a part of the organization and unconsciously identifies himself or herself with the organization (Mignonac, Herrbach, & Guerrero, 2006). To put it differently, the higher the CoR, the higher the identification of the employees with the organization is expected (Carmeli, 2005). Therefore, CoR emerges as a key antecedent of OI (Mael & Ashforth, 1992). However, the number of studies investigating relationships between OI & OD and CoR are very few. Thus, we hypothesize;

H2: CoR will have a positive impact on OI.

Studies in the OI literature have mainly focused on the overlapping of individual and organizational identities. However, management researchers are looking at identification from a broader perspective since identification is a complex issue, and there may be different forms of identification. In this regard, some authors put forward the concept of "disidentification". It should be noted that identification and disidentification, which at first glance seem to represent a bipolar unidimensional variable, are in fact separate variables expressing different psychological states (Ashforth, 2001; DiSanza & Bullis, 1999; Dukerich et al., 1998; Elsbach, 1999, 2001; Pratt, 2000). In particular, the studies of two groups of scholar has provided some information about the antecedents of disidentification. Elsbach and Bhattacharya (2001) suggest two antecedents concerning disidentification: 1) the employee of the organization has values that do not match with the corporate identity that he/she sees as negative; and 2) the perception that the reputation of an organization may adversely affect the personal reputation of the employee. Similarly, Costas and Fleming (2009) argue that self-alienation created by the loss of reputation or ambivalent identity of the organization may act as a trigger of disidentification.

Disidentification comes to the fore as one of these different forms of identification (Ashforth, 2001; DiSanza & Bullis, 1999; Dukerich et al., 1998; Elsbach, 1999; Pratt, 2000). It occurs when the individuals could not internalize the norm or values that define the organization (Elsbach & Bhattacharya, 2001). Especially at a point where employees consciously or actively separate their own identities from the components that define the organization's mission, culture, or others, they may probably hide some aspects of the organization that seem to be objectionable to others, and may even lie about their company (Elsbach, 1999; Kreiner & Ashforth, 2004). Therefore, disidentification indicates an undesirable one as it represents the result of deep conflicts felt between the member and the organization.

When the subject is approached in terms of CoR, it is seen that a positive perception of CoR protects employees from issues that may weaken their identification, while a negative perception of CoR leads to disidentification by reducing individuals' desire to improve themselves. Employees who do not identify themselves with their organizations can be just as harmful to their organizations as employees who are identify themselves with their organizations are beneficial for their organizations. Those employees represent a group that needs extra attention (Horn & Griffeth, 1995). Thus, we hypothesize;

H3: CoR will have a negative impact on OD.

Another critical factor that may influence individuals' identification with the organization is how they perceive the CI. According to Dutton and Dukerich

(1991: 550). "*The relationship between individuals' senses of their CI and image and their sense of who they are and what they stand for suggests a very personal connection between organizational action and individual motivation.*" CIS creates the perception of having similar goals, values, and interests with other members, which stimulates employees' intrinsic motivation to support organizational processes and take more responsibility (Edwards, 2005; De Roeck et al., 2014). Different research findings show that employees who identify themselves strongly with their organizations are much more "beneficial" for the corporation (Smidts et al., 2001) as it enables the employees to act in line with organizational interests (Ashforth & Mael, 1989; Edwards, 2005; De Roeck et al., 2014). A sense of identification exhorts employees to display higher levels of cooperation and supportive actions and devote more effort to the organization (Riketta, 2005; Lee et al., 2015). Managing CI creates a shared spirit of comradeship that leads members to work in unity and, in turn, provides several positive outcomes, including the employees' identification with the organization's internal culture and values (Dutton et al., 1994). Therefore, we hypothesize;

H4: CIS will have a positive impact on OI.

Disidentification is a separate variable which expresses a different psychological state of individual. Interestingly, how individuals disidentify themselves from the organization still remains unclear, and the concept of organizational disidentification has not drawn much academic attention (Chang et al., 2013:473). For this reason the importance of corporate identity and various forms of identifications is also growing (Elsbach & Bhattacharya, 2001; Costas & Fleming, 2009; Balmer, 2011; Podnar & Golop, 2015:216; Chang et al., 2013). The current study clarifies the concept organizational disidentification by exploring the effects of CIS and COR on OD and adds new insight to the OB literature.

Disidentification expresses a conscious and active disagreement of the individual with CIS, not incidental or exemplary conflict of intent (Elsbach, 1999). To put it differently; it may be a discrepancy or inconsistency between the individual's identity and the CIS. The employee's defining himself/herself as partly the same and somewhat different with his / her organization causes various effects on the person and the organization (Kreiner & Ashforth, 2004). Therefore, we hypothesize:

H5: CIS will have a negative impact on OD.

1.3 Corporate identity strenght, reputation, and firm performance

The conceptualization and measurement of organizational performance have long been a matter of concern for management and OB scholars. Nevertheless, as mentioned in the introduction part, there is no consensus among scholars

regarding the definition of performance and its measurement, given its complexity. Some studies consider performance a unidimensional concept; many others claim that it involves different facets and issues, just like reputation. For instance, from a comprehensive perspective, Santos and Brito (2012) argue FP to be composed of financial reputation, market value, profitability, customer satisfaction, employee satisfaction, environmental performance, and social performance; while Rowe and Morrow (1999) claim that financial performance involves financial reputation, market value, and profitability.

Another issue rising in performance measurement is using self-reported and perceptual indicators versus objective ones. Although self-reported performance measures are subjective and they create some hesitations due to their subjective nature, many studies have provided empirical evidence in support of a strong correlation between objective and self-reported performance measures (Dawes, 1999; Dess & Robinson, 1984; Delaney & Huselid, 1996; Dollinger & Golden, 1992; Powell, 1992; Richard et al., 2009; Venkatraman & Ramanujam 1987; Wall et al., 2004). Moreover, objective performance measures are found to be more convenient for financial performance measurement (Ketokivi & Schroeder, 2004). Specifically, if we are talking about financial institutions (e.g., banks), objective measures in terms of financial ratios are accessible and useful as they are publicly announced. For instance, Al-Hawari and Ward (2006) used asset utilization (AU), return on assets (ROA), and return on equity (ROE) ratios for measuring the financial performance of banks. In this paper, following Al-Hawari and Ward (2006), we also used asset utilization, ROA, and ROE ratios in addition to the primary self-reported measures to measure financial performance.

After shedding light on the measurement of the study's performance preferences, it is useful to look at the relationship among perceived CIS, CoR, and FP. A great number of studies have been conducted to explore how firms' corporate reputations influence their financial performance and drawn our attention to the positive relationship between reputation and financial performance (Ansong & Anyemang, 2016; Carmeli & Tishler, 2006; Dunbar & Schwalbach, 2000; Lee & Roh, 2012; Neville et al., 2005). In a recent study, Goker et al. (2017) examined the CoR of 16 firms that were listed as "Turkey's Most Admired Companies" in Capital 2014, and found out that CoR is significantly and positively associated with the firm performance, which is measured through stock prices. Nevertheless, that positive effect is also considered to be dependent on firm characteristics, including firm size, capital intensity, R&D intensity, and debt leverage ratio. Similarly, Tracey (2014) empirically supported corporations' strong financial and service reputation that allow for superior financial performance by controlling for firm size and previous financial performance. Moreover, studies testing the mediation effect of CoR on FP also confirm the positive

relations (Nguyen et al., 2021; Pham & Tran, 2020), which leads to conclusion that CoR has both direct and indirect effects on FP.

The existing literature underlines that a superior CoR can provide many benefits, for instance, enabling firms to charge premium prices; reducing firm costs and employee turnover; attracting applicants, investors, and customers; increasing repurchases, customer retention, and profitability; and improving firm value (Eberl & Schwaiger, 2005; Fombrun & Shanley, 1990; Roberts & Dowling, 2002; Walker, 2010). Customers prefer firms with a good reputation, and CoR plays an essential role in shaping customers' behavioral intentions (Keh & Xie; Park et al., 2014), which is likely to increase subjective-perceived FP. Accordingly; we hypothesize;

H6: CoR will have a positive impact on subjective- perceived FP.

Given the aforementioned debates about using subjective measures of performance with self-reported measures, we decided to strengthen our study by adding objective measures. Following Al-Hawari and Ward (2006), we use asset utilization (AU), return on equity (ROE), and return on assets (ROA) as objective measures for performance. Return on assets (ROA) is an indicator of how profitable a company is relative to its total assets. ROA gives a manager, investor, or analyst an idea of how efficient a company's management is at using its assets to generate earnings. Return on equity (ROE) is a well-known measure of performance estimated by dividing net income by using shareholders' equity. Since shareholders' equity is equal to a company's assets minus its debt, ROE is regarded as the return on net assets. (Warrad & Al Omari, 2015). On the other hand, the asset utilization ratio estimates the total revenue earned for every penny of assets a company possesses. This ratio is commonly employed to evaluate a company's efficiency over time. Asset Utilization (AU) is considered to be the true measure of how well a company is using its capacity (Rahayu, 2019). Accordingly, we hypothesize;

H7: CoR will have a positive impact on the objective measures of FP a) AU, b) ROA, and c) ROE.

While multiple studies draw the link between favorable CoR and superior FP, the positive effects of CIS studies in academic research are rare, especially with the evidence in the banking sector. Although marketing scholars reported that CI directly influences customer orientation, which positively impacts FP (i.e., Beckman & Harris, 2007; Maurya et al., 2015), the impact of CIS on FP is only investigated by Boehm and colleagues (2015) in the literature. In that study, both CEO charisma and transformational leadership climate are proposed to increase CIS which in turn, relates positively to FP.

Voss, Cable, & Voss (2006) presented how divergent views of top-level leaders relating to CI led to lower performance in nonprofit professional theatres. If organizations cannot project a strong and unified identity for employees to follow, their performance is likely to decrease due to the lack of a common point of reference. A poorly projected identity is likely to confuse external stakeholders with negative effects on internal stakeholders' motivation, identification, and persistence. Therefore, a good reputation aligned with CIS is likely to enhance the performance of the company, and thus it is proposed;

H8: CIS will have a positive impact on subjective-perceived FP.

H9: CIS will have a positive impact on the objective measures of FP a) AU b) ROA, and c) ROE.

Figure 1 – Research model

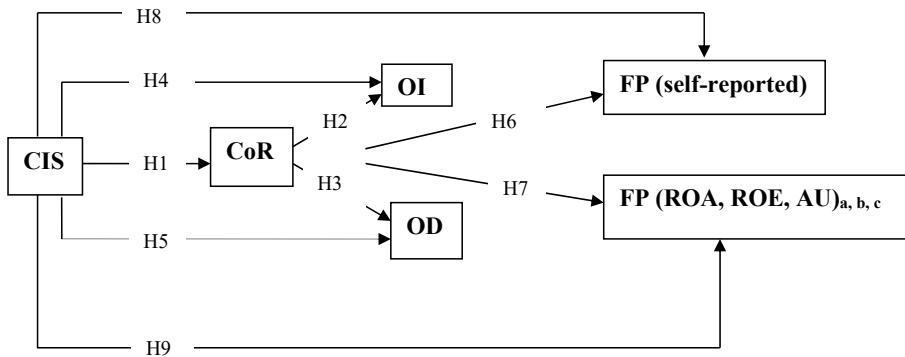

2. Methodology

2.1 Measures

To test the above-mentioned hypotheses, multi-item scales are adopted from prior studies for the measurement of variables. Each variable was measured using a 5-point Likert scale ranging from “strongly disagree” (1) to “strongly agree” (5). The appendix demonstrates the measures of the study. In order to measure the CIS, 9-item scale was used by adapting 4 items from Kreiner and Ashfort’s (2004) and 5 items developed by Gioia and Thomas’s (1996) identity strength scales. “There is a common sense of purpose in this organization”, “Corporation’s managers and employees identify strongly with the corporation” can be given as examples of the scale items.

OI scale developed by Mael and Ashforth (1992) was used to measure identification of employees. This scale consists of 6 items such as “When someone criticizes my organization, it feels like a personal insult”, “When I talk about this organization, I usually say ‘we’ rather than ‘they’”. In order to measure

disidentification, the 6-item scale, developed by Kreiner and Ashfort (2004) was used. “This organization does shameful things”, “I want people to know that I disagree with how this organization behaves” can be given as examples of the scale items.

CoR as a second-order construct composed of five-dimensions in terms of emotional appeal, products and services, vision and leadership, workplace environment and social and environmental responsibility was used as endogenous variables. The scale which consisted of 16 items adapted from Fombrun, Gardberg, & Sever (2000). “I have a good feeling about the company” (emotional appeal), “This company offers high quality products and services” (products and services), “This company has a clear vision for its future” (vision and leadership), “This company is well managed” (workplace environment), “This is an environmentally responsible company” (social and environmental responsibility), are some examples of the items in the scale.

FP is an indicator of a firm’s capacity to achieve its goals (Venkatraman & Ramanujam 1986). Following Venkatraman & Ramanujam’s (1986) view, we adopted a scale developed by Zehir, Gurolb, Karabogac, & Koled (2016) composed of four items. “This company has an above-average profitability”, “This company has an above-average sales volume” can be given as examples of the scale items. Moreover, as our sample is composed of 54 banks that are registered in The Banks Association of Turkey and Participation Banks Association of Turkey, we also employed the secondary data for financial performance including return on assets (ROA), return on equity (ROE) and asset utilization (AU) ratios. From the website of The Banks Association of Turkey and Participation Banks Association of Turkey, five-year (2016 – 2020). average of ROA, ROE and AU ratios are calculated.

2.2 Sampling

The purpose of this paper is to describe and analyze the mutual relationships among the CIS, CoR, OI, OD and FP. This study is conducted on a total of 54 banks registered in The Banks Association of Turkey and Participation Banks Association of Turkey. We have reached all banks in the banking sector. Within the scope of the research, data on CIS and OI and OD, and FP were gathered from bank employees, and data on CoR were gathered from banks' corporate customers in April, May and June 2020, and meanwhile, the secondary data regarding financial performance –in terms of ROA, ROE and AU ratios- were obtained from the tables of selected ratios in the statistical report tables of 2016-2020 in the website of The Banks Association of Turkey and Participation Banks Association of Turkey. These tables are included in the bank and sector information section of the relevant websites. So we had two separate questionnaire forms for the research, one for bank employees and the other for the

customers. In order to avoid single-source bias, two respondents at managerial levels from the banks, and two corporate customers for each bank participated in the survey. All respondents were informed that the data would remain anonymous and would not be linked to them individually, to their company, or to the company products. In addition, respondents were assured that there were no right and wrong answers and thus they should answer questions as honestly and forthrightly as possible. As a result, we had a total of 216 completed surveys -2 bank employees from each 54 bank and 2 corporate customers from each 54 banks- were included in the analysis. And also, five year average of ROA, ROE and AU ratios of these banks were calculated.

The findings are based on data from a convenience sample of 108 bank employees and 108 banks' corporate customers. Related to bank employees; 68% of the participants were male, 86% were married, all of the participants held university diplomas or higher degrees, 49% were between the ages of 26 – 35, 36% held seniority between 4 – 6 years, and 55% were middle line managers. Related to banks' corporate customers; 76% of the participants were male, 84% were married, 57% held college diplomas or higher degrees, 42% were between the ages of 36 – 45, 36% held seniority between 4 – 6 years, and 43% were middle line managers.

3. Results and discussion

3.1 Analysis

The PLS-SEM technique was used to estimate the measurement and structural parameters in our structural equation model (SEM) (Chin, 2001). Before performing any analysis, the firm scores of each question item were aggregated since the level of analysis is the “firm”. The inter-rater agreement (rwg) on organizational level measures was needed to be demonstrated and all rwg values ranged from .67 to .82. The ranging values of interrater agreement in context with the study is well above .60 which is considered as a benchmark (Hurley & Hult, 1998), indicating a satisfactory level of inter-rater agreement for each aggregate measure in banks (see Appendix).

We used PLS-SEM technique to test our model based on several considerations. First, PLS method can operate under a limited number of observations with more discrete or continuous variables. Since there are 54 banks operating in banking industry in Turkey and we succeeded to gather data from them all, our sample size is 54. PLS is the proper technique for such a small sample. PLS is also a latent variable modeling technique that incorporates multiple dependent constructs and explicitly recognizes measurement error (Karimi, 2009). Also, PLS is far less restrictive in its distributional assumption and applies to situations where knowledge about the distribution of the latent variables is limited.

PLS requires the estimates to be more closely tied to the data compared to covariance structure analysis (Fornell & Cha, 1994).

3.2 Measurement validation

In this study, following Kleijnen, Ruyter, and Wetzels (2007), we used reflective indicators for all our constructs. To assess the psychometric properties of the measurement instruments, we estimated a null model with no structural relationships. We evaluated reliability using composite scale reliability (CR), Cronbach alpha and average variance extracted (AVE). For all measures, PLS-based CR is well above the threshold value of .70, Cronbach alpha goes beyond the threshold value of .70 and AVE exceeds the .50 threshold value (see Table 1). In addition, we evaluated convergent validity by inspecting the standardized loadings of the measures on their respective constructs and found that all measures exhibit standardized loadings that exceed .60 (see Appendix A). Moreover, as a second order variable, CR was estimated through a secondary factor analysis yielding five latent constructs: emotional appeal, products and services, vision and leadership, financial appeal, and social and environmental responsibility. Each of three constructs –emotional appeal, products and services, and vision and leadership had three indicators while financial appeal and social and environmental responsibility had five. Figure 2 shows the standardized regression loadings of those given five constructs. As seen in Figure 2, all five constructs exceed a standardized loading over .60. This result suggests that CR, as a five construct second level variable, is significantly predicted by emotional appeal, products and services, vision and leadership, financial appeal, and social and environmental responsibility.

Figure 2 – Second order factor analysis of corporate reputation

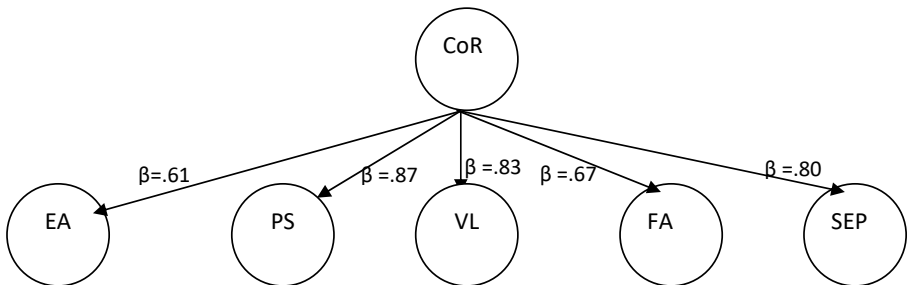

Note. CoR: Corporate reputation, EA: Emotional appeal, PS: Products and services, VL: Vision and leadership, FA: Financial appeal, SEP: Social and environmental responsibility

We then assessed the discriminant validity of the measures. Table 1 shows the correlation among all variables -excluding the secondary data on firm performance- which provides further evidence of discriminant validity. To fully satisfy

the requirements for discriminant validity, AVE for each construct should be expected to be greater than the squared correlation between constructs (Fornell & Larcker, 1981). Such results suggest that the items share more common variance with their respective constructs than any variance the construct shares with other constructs (Howell & Aviolo, 1993). In the model, none of the inter-correlations of the constructs exceeded the square root of the AVE of the constructs (see Table 1).

Table 1 – Discriminant validity

No		1	2	3	4	5	6	7	8	9
1	EA	0.834								
2	FA	0.378	0.761							
3	FP	0.516	0.593	0.788						
4	CIS	0.259	0.209	0.446	0.721					
5	OD	-0.197	-0.269	-0.403	-0.63	0.978				
6	OI	0.115	-0.164	-0.095	-0.20*	0.548	0.915			
7	SEP	0.412	0.471	0.493	0.22	-0.183	-0.180	0.941		
8	PS	0.395	0.397	0.627	0.41;	-0.119	-0.098	0.623	0.767	
9	VL	0.257	0.479	0.631	0.42	-0.259	-0.178	0.573	0.733	0.820
	α	0.779	0.650	0.799	0.866	0.978	0.971	0.870	0.755	0.756
	CR	0.872	0.802	0.867	0.895	0.985	0.962	0.939	0.846	0.860
	AVE	0.695	0.580	0.622	0.518	0.957	0.837	0.885	0.588	0.672

* $p < .05$, ** $p < .01$.

Note₁. Diagonals show the square root of AVEs.

Note₂. EA: Emotional appeal, PS: Products and services, VL: Vision and leadership, FA: Financial appeal, SEP: Social and environmental responsibility, FP: Firm performance, CIS: Corporate identity strength, OI: Organizational identification, OD: Organizational disidentification, CR: Composite reliability, AVE: Average variance extracted, α : Cronbach's alpha

3.3 Assessment of common method variance

We used Harman's Single Factor (Harman, 1960) by utilizing EFA with all variables –excluding AU, ROA and ROE- loaded onto a single factor without a rotation. The new common latent factor explained only 29.90% of the variance, which is less than the cut-off value of 50%.

Kock (2015) proposed that a model with greater than 3.3 variance inflation factors (VIFs) is an indication of a CMV issue. The results of our VIFs analysis demonstrate that the VIFs values range between 1.21 and 1.22, i.e., the values are lower than the suggested threshold of 3.3. Thus, the proposed model does not appear to be affected by common method bias.

3.4 Hypothesis testing

The PLS approach (Ringle et al., 2005) and the bootstrapping re-sampling method (Chin, 1998) were employed by computing the SmartPLS 3.0 software program to test the hypothesis and predictive power of the proposed model (see Figure 1). This procedure entailed generating 5000 sub-samples of cases (Hair et al., 2013) that were randomly selected, with replacement, obtained from the original data, after which path coefficients were generated for each. T-statistics were performed for all coefficients, based on their stability across the sub-samples, in order to determine the links that were statistically significant. The path coefficients and their associated t-values demonstrated the direction and impact of each hypothesized relationship.

Table 2 – Hypothesis testing results

Hypothesis	Relationships	Path coefficient (β)	Results
H1	CIS→CoR	0.421**	Supported
H2	CoR → OI	-0.054	Not supported
H3	CoR→OD	0.007	Not supported
H4	CIS→OI	-0.078	Not supported
H5	CIS→OD	-0.633**	Supported
H6	CoR→FP	0.683**	Supported
H7a	CoR → AU	0.174*	Supported
H7b	CoR →ROA	0.159*	Supported
H7c	CoR → ROE	0.111	Not supported
H8	CIS→FP	0.156	Not supported
H9a	CIS→AU	-0.137	Not supported
H9b	CIS→ ROA	-0.129	Not supported
H9c	CIS → ROE	0.086	Not supported

* $p < .05$, ** $p < .01$.

Note. CoR: Corporate reputation, FP: Firm performance (subjective), CIS: Corporate identity strength, OI: Organizational identification, OD: Organizational disidentification, ROA: Return on assets, ROE: Return on equity, AU: Asset utilization

Table 2 shows the results of hypotheses, including paths, beta values and significance levels. Concerning the antecedent role of CIS on CoR, the results reveal that CIS has positive impact on CoR ($\beta = .42$ $p < .01$), supporting H1. Our research model also examines the effects of CIS on OI, OD and performance variables. Our findings show that CIS is positively and significantly associated with OD ($\beta = -.63$ $p < .01$), while the results provide no empirical evidence to support a statistically significant relationship between CIS and OI or between CIS and any of the other performance variables. The results provide no empirical evidence to support a statistically significant relationship between CIS and OI or between CIS and any of the other performance variables. Therefore, only H5 is supported. Regarding the influences of CoR on objective firm performance variables, the findings revealed that CoR is positively related with AU ($\beta = .17$

$p < .05$), ROA ($\beta = .30$ $p < .05$) and subjective (perceived) firm performance ($\beta = .68$ $p < .01$), therefore H6, H7a, H7b are supported. The results of research indicated that CIS has no effect on objective financial performance variables (AU, ROA, ROE) and subjective-perceived firm performance (FP), therefore H9 is not supported fully.

Moreover, we also performed mediation analysis to assess the indirect effects of CIS on performance outputs -in terms of both self reported and objective measures-, through CoR. With the inclusion of mediating variable CoR, the impact of CIS on FP ($\beta = .156$; $p > .05$) becomes insignificant. However, the indirect effect of CIS on FP ($\beta = .444$; $p < .01$) was significant. This finding indicates that the relationships between CIS and FP is fully mediated by CoR. However, since total effects of CIS on objective performance measures (i.e., AU, ROA and ROE) are all insignificant, the findings provide no empirical evidence in support of an indirect effect of CIS on any objective performance measures.

Table 3 – Results for the mediating analyses

Total effect		Direct Effect		Indirect Effect			
Relationship	(β)	Relationship	(β)	Relationship	(β)	BI[2.5%;97.5%]	
CIS→FP	.444**	CIS→FP	0.156	CIS→CoR→FP	.288**	.107	.447
CIS→AU	-.064	CIS→AU	0.137	CIS→CoR→AU	.073	-.010	.191
CIS→ROA	-.062	CIS→ROA	0.129	CIS→CoR→ROA	.067	-.013	.178
CIS→ROE	.039	CIS→ROE	0.086	CIS→CoR→ROE	-.047	-.179	.098

4. Discussion

This research contributes to OB literature by presenting a model of interrelationships among CIS, CoR, OI, OD, and FP. By highlighting the antecedent role of CIS on CoR and firm performance in the banking industry from a bi-stakeholder perspective, this study offers a framework for researchers and managers to visualize and understand the relationships between corporate-level constructs and individual and firm-level outputs, thus enhancing the movement of the Social Identity Theory in OB literature. This study, specifically, makes four contributions to the literature.

First, this study empirically investigated the antecedent role of CIS on CoR. Our results showed that CoR is a reflection of corporate identity; the stronger the identity, the superior the reputation. Hence, in line with the existing literature (e.g., Christensen & Askegaard, 2001; Argenti & Druckenmiller, 2004; Abratt & Kleyn, 2011), our findings underline the importance of CIS in creating and maintaining a positive CoR perception on stakeholders (e.g., employees, customers..). As Melewar (2003) addresses, senior management's efforts to create

a visible and strong CIS contribute to establishing the foundations of the company's reputation. Moreover, those efforts can shape stakeholders' perceptions regarding the firm", market share, managerial and competitive power, business capacity, product, and service range.

In addition, since we gathered CIS data from employees and CoR data from customers, this result emphasizes another aspect of CoR. The employees are of significant importance due to their roles in establishing and maintaining a favorable CoR. When the CI is widely shared and deeply internalized among the employees, those employees transfer that identity to the stakeholders to strengthen the CoR. Employees may feel proud of working for their organizations, and they may act with self-esteem to create a good impression on the customers. Therefore, an affirmative CoR may be established by the effective communication and interaction between employees, customers, and the other stakeholders. This finding is parallel to Helm's (2007) study, which emphasizes the employees' priority role in creating corporate assets or corporate value through the fulfillment of the brand promise given to the stakeholders. This is particularly more significant for the service industry since the service industry requires intense communication between employees and customers.

Second, this research adds new insight to the OB literature regarding the reflections of CIS on OI, and specifically on OD. Based on how individuals disidentify themselves from the organization, it remains unclear, with under-developed theories and scant studies (Riketta, 2005; Chang et al., 2013). Our findings indicate that widely entrenched identity beliefs among the employees (i.e., the strength of employees' identity perceptions) are necessary to prevent OD; however, it is not a sufficient condition for ensuring OI. The existing literature considers CI as a basis for OI (e.g., Dutton, Duckerich & Harguail, 1994; Hatch & Schultz, 2000; Witting, 2006). Furthermore, there are even some scholars that argue a dual relationship between CI and OI (e.g., Stanske, 2017). Indeed, OD is a specific type of OI (Kreiner & Ashforth, 2004). Hence our findings do not mean that CIS has no relationship with OI; rather, it is a starting point for preventing OD; ensuring OI requires more.

Third, interestingly, we could not find any direct statistical association between CoR, OI, and OD. This finding is in contrast with the existing literature, which considers CoR as one of the most influential determinants of OI since members feel proud to belong to an organization that is believed to be reputable in public (Dutton et al. 1994; Oncer & Yıldız 2012). In addition, Podnar and Golob (2015) find out that CoR is positively associated with OI in terms of perceived external prestige. Moreover, many studies (e.g., Mael & Ashforth, 1992; Bhattacharya et al., 1995; Pratt, 1998; Fisher & Wakefield, 1998; Oncer & Yıldız 2012) also provide empirical evidence in support of an antecedent role of CoR for OI. Thus, our findings do not mean that CoR has no relationship with

OI and OD because, in this study, we gather OI and OD data are from employees while we gather CoR data from the customers. The results may differ for data in which CoR, OI, and OD are gathered from employees.

Fourth, we found a positive relationship between a CoR and firm performance, both in terms of subjective and objective performance measures. Indeed, the existing literature on CoR and FP has conflicting results. Some studies find no causal link between reputation and financial outcomes of the firm (e.g., Rose & Thomsen, 2004; Inglis et al., 2006; Sanchez & Sotorrio, 2007; Caliskan et al., 2011), while some others provide empirical evidence in support of the positive relationship (e.g., Vidaver-Cohen, 2007; Lei, 2011; Flanagan et al., 2011; Gok & Ozkaya, 2011; Park et al., 2014). Consistent with the latter ones, our findings underline the fact that CoR is an essential strategic asset with significant reflections on performance. This means that customers' collective perceptions about the company based on its history and its future prospects shape the customers' behavioral intentions for the benefit of those firms. Moreover, Foroudia et al. (2020) emphasize sustainable competitive advantage as the proximal mechanism between CoR and firm performance and claim firm competitiveness to be contingent on its reputation, connected to its identity and heritage. Those arguments and findings might explain why many management and OB researchers attach high importance to CoR. By contributing to the target audience's trust and value creation, maximizing the ability to offer products and services with high added value, CoR leads to superior financial performance. Remarkably today's bank customers view their relationship with their banks more as a personal relationship than a business one, and like most intimate relationships, they expect it to be built first and foremost upon trust (Beatty, A. October 24, 2019). Moreover, having a good reputation means that stakeholders are quite certain about the organization's future performance in general and financial performance in particular. Based on the reason that bank customers expect great value and return from banks' financial products and services (Microsoft Industry Blogs), a good CoR may contribute to establishing and maintaining trust among the customers, regarding the great value and return from banks' financial products and services, which in turn leads to higher performance for banks.

Also, this finding supports the argument that self-reported and perceptual performance indicators have a strong correlation with objective performance measures (Dess & Robinson, 1984; Venkatraman & Ramanujam 1987; Dollinger & Golden, 1992; Powell, 1992; Delaney & Huselid, 1996; Dawes, 1999; Richard et al., 2009; Wall et al., 2004) as the CoR has been shown to have a similar association with both perceptual performance and two objective performance measures in terms of ROA and AU. Therefore, even though there are some hesitations due to their subjective nature, self-reported and perceptual performance indicators are shown to be as useful as the objective ones.

Fifth, regarding the CIS and performance relationship, the findings indicate that CIS is not directly associated with firm performance both for self reported performance measures and the objective ones. This result doesn't mean that CIS doesn't have any ultimate effect on performance. However, the positive covariances amongst CIS, CoR, and FP imply that CIS may indirectly impact FP through other proximal mechanisms. Even though we didn't involve in the hypothesis development and methodology parts, we also checked the mediator role of CoR on the relationship between CIS and performance outputs. The findings show that CoR mediates the relationship between CIS and self reported firm performance, while they provide no empirical evidence regarding such a mediator role of CoR for the objective performance measures. This result means that even though we gather CIS data are from employees, CoR data from the customers, and FP from managers, all those perceptions of different stakeholders seem to be coherent with each other. So, this finding deepens our understanding regarding the impact of CIS on firm performance by addressing the CoR as a mechanism that connects CIS and FP, at least at the perceptual level.

Overall, the results of this study are useful since they add further insights to the literature regarding the individual and organizational consequences of CIS and CoR. Our holistic model highlights the CIS as an essential antecedent of CoR, and CoR to be positively related to FP. Moreover, our findings reveal that CIS only forms the basis for OI, while strengthening OI requires greater managerial effort. Finally, the results also provide support for the congruency of the perceptual and self-reported performance measures

4.1 Theoretical implications

From a theoretical point of view, this study offers significant contributions and insights into the SIT theory. SIT assumes that individuals derive part of their identity – their social identity- from the groups they belong to (e.g., student, alumni, football team, etc.) (Willetts & Clarke, 2014; Scheepers & Ellemers, 2019). According to Tajfel (1979), those groups, people belonged to, are vital sources of pride and self-esteem. Our findings suggest that CIS is associated with superior CoR through the lens of customers in general, bank customers in particular. Therefore we enlarged SIT by revealing that a strong social identity (i.e., CI), widely internalized by the members, also creates a good impression on the third parties (i.e. customers) in terms of prestige, reputation, and cachet, as well as providing a sense of belongingness to the members. We also find out that CIS is a necessary but not a sufficient condition for OI. Thus we contribute to the SIT by addressing that even social identity forms a basis for identification; organizations in general, specifically bank organizations, should invest more in their human capital to enable their employees to identify themselves with the organization, leading to productive work behaviors.

4.2 Managerial implications

As well as enriching the literature on SIT, the presented model, hypotheses, and the results, which explain the complex mechanism between corporate related variables, individual and organizational outcomes, may also have implications for managers in general, specifically for the bank managers. First of all, this paper underlines the fact a strong CI, shared and internalized and reflected by the employees is a basic determinant of CoR from customer perspective. Accordingly, in establishing and maintaining, management should take the necessary steps to invest in their human capital. Management should also follow a participative leadership style and involve employees more in decision making process. Another essential suggestion for managers is to implement procedures to develop and reinforce a psychological contract with the employees; since employees may perform greater effort to fulfill their responsibilities and to demonstrate extra-role behaviors due to the reciprocity between them and the management.

Second, this study indicates CoR as an important precursor of FP. Management should be aware of the fact that CoR is one of the most valuable intangible resources and probably strategic tools that provides sustainable competitive which ultimately leads to higher firm performance. Hence, management should involve CoR within organizational strategy and adequately manage this strategic tool to achieve higher performance outputs. Third, the findings of this study show that CIS forms just the basis for identification as a necessary condition but not sufficient one. So, without a doubt, management should try to spread the identity signifiers among organizational members. Moreover, in order to build a strong identification, they should also cultivate emotional bonds among employees to increase the job engagement, the organizational commitment and loyalty. They may also foster an ongoing dialogue and interactions among employees at after-work meetings and parties to develop a meaningful bridge to the organization.

4.3 Limitations and future research

The findings of this paper should be considered cautiously due to its strengths and limitations, which also address future research directions. A key strength of the present paper is that CIS, OI, OD and self reported FP data is gathered from bank managers; while we conducted CoR survey on customers. In addition we also added the objective performance measures –ROA, ROE and AU- to our research model, in addition to the self reported performance measures. Accordingly our paper is unique in that the findings are based on the analysis of the data from bi-stakeholders (i.e., employees and customers) and objective performance measures. Hence, we believe that results reported here are not prone to social desirability bias.

In addition to those strengths, there are several limitations to be considered. Thus, researchers should be careful when generalizing the results to different industries and cultural contexts. First of all, we conducted this research on a specific national and industrial context, Turkish banks. Banks and other financial service organizations present different characteristics than the others. Since they deal with monetary issues, there is a rigid hierarchy and strictly defined duties within the banks.

Moreover, in Turkey, an emerging and turbulent economy, technology and market uncertainties are less intensive and complicated than the western and developed countries' ones. Likewise, having a near-eastern culture, empathy among employees, and even among customers and employees, and the sense of identification to the organization may be different from other nationalist cultures. On the other hand, tolerance for mistakes is less acceptable than in other cultures. Thus, a Turkish sample, just like any culturally bound research, has some limitations regarding the interpretation of the results.

Employing a cross-sectional design with surveys seems to be another limitation of this paper. Despite the fact that "surveying is a large and growing area of research in the natural environment" (Graziano & Raulin, 1997), the technique utilized –surveys- may not provide objective outcomes about the reflections of CIS and CoR on individual outcomes and performance measures which is inherently a dynamic process. To overcome this limitation, future researchers may conduct longitudinal studies in which the reflections of CIS and CoR can be followed over time.

In addition, we gathered CoR data from only one stakeholder (e.g., customers). However, to paint a more accurate CoR, future studies may consider collecting CoR data from multi-sources (e.g., customers, employees, suppliers, etc.). Furthermore, in this study, we operationalize CoR as a composite variable. One should investigate this construct in great detail, including its antecedents and consequences. Future studies may also employ a multi-dimensional CoR construct to see how CIS affects each dimension and how each dimension is reflected on FP. This research scratches the surface of these important but relatively unexplored relationships. Future researchers will find the area of CIS and CoR rich and fruitful for management and OB literature.

References

- Abrams, D. (1996). Social identity, self as structure and self as process. In W. P. Robinson (Ed.), *Social groups and identities: Developing the legacy of Henri Tajfel* (pp. 143-167). Oxford, UK: Butterworth-Heinemann.
- Abratt, R. & Kleyn, N. (2011). Corporate identity, corporate branding and corporate reputations: Reconciliation and integration. *European Journal of Marketing*, 46(7/8), 1048–1063.

- Albert, S. & Whetten, D. A. (1985). Organizational identity. In L. L. Cummings & B. M. Staw (Eds.), *Research in organizational behavior* (pp. 263-295). Greenwich, CT: JAI Press.
- Al-Hawari, M. & Ward, T. (2006). The effect of automated service quality on Australian banks' financial performance and the mediating role of customer satisfaction. *Marketing Intelligence & Planning*, 24(2), 127-147.
- Ansong, A. & Agyemang, O. S. (2016). Firm reputation and financial performance of SMEs: the Ghanaian perspective. *Euromed Journal of Management*, 1(3), 237-251.
- Argenti, P. A. & Druckenmiller, B. (2004). Reputation and the corporate brand. *Corporate Reputation Review*, 6(4), 368-374.
- Ashforth, B. E. & Mael, F. (1989). Social identity theory and the organization. *Academy of Management Review*, 14(1), 20-39.
- Ashforth, B. E. (2001). *Role Transitions in organizational life: An identity-based perspective*. New York: Routledge.
- Avanzi, L., Schuh, S. C., Fraccaroli, F. & van Dick, R. (2015). Why does organizational identification relate to reduced employee burnout? The mediating influence of social support and collective efficacy. *Work & Stress*, 29(1), 1-10.
- Balmer, J. M. T. (2011). Corporate marketing myopia and the inexorable rise of a corporate marketing logic: Perspectives from identity-based views of the firm. *European Journal of Marketing*, 45(9/10), 1329-1352.
- Barnett, M. L., Jermier, J. M. & Lafferty B. A. (2006). Corporate Reputation: The Definitional Landscape. *Corporate Reputation Review*, 9(1), 26-38.
- Barney, J. B. (2000). Firm resources and sustained competitive advantage. In J. A. C. Baum, & F. Dobbin (Eds.), *Economics Meets Sociology in Strategic Management (Advances in Strategic Management, Vol. 17)* (pp. 203-227). Bingley, UK: Emerald Group Publishing.
- Beckman, T. & Harris, G. (2007). The apple of Jobs' eye: An historical look at the link between customer orientation and corporate identity. In *Proceedings of the Conference on Historical Analysis and Research in Marketing* (Vol. 13, pp. 1-12).
- Beatty, A. (FIS October 24, 2019). How banks find certainty in an uncertain world. <https://www.fisglobal.com/en/insights/what-we-think/2019/october/how-banks-find-certainty-in-an-uncertain-world>
- Bhattacharya, C. B., Rao, H. & Glynn, M. A. (1995). Understanding the bond of identification: An investigation of its correlates among art museum members. *Journal of Marketing*, 59(4), 46-57.
- Bromley, D. B. (2001). Relationships between personal and corporate reputation. *European Journal of Marketing*, 35(3/4), 316-334.
- Boehm, S. A., Dwertmann, D. J. G., Bruch, H. & Shamir, B. (2015). The missing link? Investigating organizational identity strength and transformational leadership climate as mechanisms that connect CEO charisma with firm performance. *The Leadership Quarterly*, 26, 156-171
- Caliskan, E., Icke, B. & Ayturk, Y. (2011). Corporate reputation and financial performance: Evidence from Turkey. *Research Journal of International Studies*, 18(1), 61-72.
- Carmeli, A. (2005). Perceived external prestige, affective commitment, and citizenship behaviors. *Organization Studies*, 26, 443-464.

- Carmeli, A. & Tishler, A. (2006). The relative importance of the top management team's managerial skills. *International Journal of Manpower*, 27(1), 9-36.
- Caza, B. B., Vough, H. C. & Puranik, H. (2018). Identity work in organizations and occupations: Definitions, theories, and pathways forward. *Journal of Organizational Behavior*, 39, 889–910.
- Chang, K., Kuo, C. C., Su, M. & Taylor, J. (2013). Dis-identification in organisation (DiO) and its role in the workplace. *Industrial Relations*, 68, 479 – 506.
- Chin, W. W. (1998). The partial least squares approach to structural equation modeling. *Modern Methods for Business Research*, 295(2), 295-336.
- Chin, W. W. (2001). PLS-Graph user's guide. *CT Bauer College of Business, University of Houston, USA*, 15, 1-16.
- Christensen, L. T. & Askegaard, S. (2001). Corporate identity and corporate image revisited- A semiotic perspective. *European Journal of Marketing*, 35(3/4), 292-315.
- Cole, M. S. & Bruch, H. (2006). Organizational identity strength, identification, and commitment and their relationships to turnover intention: Does Organizational Hierarchy Matter? *Journal of Organizational Behavior*, 27(5), 585–605.
- Cornelissen, J.P., Christensen, L.T. & Kinuthia, K. (2012). Corporate brands and identity: developing stronger theory and the call for shifting debate. *European Journal of Marketing*, 46(7/8), 1093-1102.
- Costas, J. & Fleming, P. (2009). Beyond dis-identification: A discursive approach to self-alienation in contemporary organizations. *Human Relations*, 62(3), 353-378.
- Dawes, J. (1999). The relationship between subjective and objective company performance measures in market orientation research: Further empirical evidence. *Marketing Bulletin (Research Note 3)*, 10, 65-75.
- De Roeck, K., Marique, G., Stinglhamber, F. & Swaen, V. (2014). Understanding employees' responses to corporate social responsibility: Mediating roles of overall justice and organisational identification. *The International Journal of Human Resource Management*, 25(1), 91-112.
- Deephouse, D. L. (2000). Media reputation as a strategic resource: An integration of mass communication and resource-based theories. *Journal of Management*, 26(6), 1091-1112.
- Delaney, J. T. & Huselid, M. A. (1996). The impact of human resource management practices on perceptions of organizational performance. *Academy of Management Journal*, 39(4), 949-969.
- Dess, G. G. & Robinson Jr, R. B. (1984). Measuring organizational performance in the absence of objective measures: The case of the privately-held firm and conglomerate business unit. *Strategic Management Journal*, 5(3), 265-273.
- DiSanza, J. R. & Bullis, C. (1999). “Everybody identifies with smokey the bear” employee responses to newsletter identification inducements at the us forest service. *Management Communication Quarterly*, 12(3), 347-399.
- Dollinger, M. J. & Golden, P. A. (1992). Interorganizational and collective strategies in small firms: environmental effects and performance. *Journal of Management*, 18(4), 695-715.
- Dowling, G. R. (1994). *Corporate reputations: Strategies for developing the corporate brand*. London: Kogan Page.

- Dukerich, J. M., Kramer, R. M., & McLean Parks, J. 1998. The dark side of organizational identification. In D. A. Whetten & P. C. Godfrey (Eds.), *Identity in organizations: Building theory through conversations*: 245–256. Thousand Oaks, CA: Sage.
- Dukerich, J. M., Kramer, R. M., & McLean Parks, J. 1998. The dark side of organizational identification. In D. A. Whetten & P. C. Godfrey (Eds.), *Identity in organizations: Building theory through conversations*: 245–256. Thousand Oaks, CA: Sage.
- Dukerich, J. M., Kramer, R. M. & McLean Parks, J. 1998. The dark side of organizational identification. In D. A. Whetten & P. C. Godfrey (Eds.), *Identity in organizations: Building theory through conversations* (pp. 245–256). Thousand Oaks, CA: Sage.
- Dunbar, R. L. & Schwalbach, J. (2000). Corporate reputation and performance in Germany. *Corporate Reputation Review*, 3(2), 115–123.
- Dutton, J. E. & Dukerich, J. M. (1991). Keeping an eye on the mirror: Image and identity in organizational adaptation. *Academy of Management Journal*, 34(3), 517–554.
- Dutton, J. E. Dukerich, J. M., & Harquail, C. V. (1994). Organizational images and member identification. *Administrative Science Quarterly*, 39(2), 239–263.
- Eberl, M. & Schwaiger, M. (2005). Corporate reputation: Disentangling the effects on financial performance. *European Journal of Marketing*, 39(7/8), 838–854.
- Edwards, S. D. (2005). *Disability: Definitions, value and identity*. Oxford, UK: Radcliffe Publishing.
- Elsbach, K. D. & Glynn, M. A. (1996). Believing your own “PR”: Embedding identification in strategic reputation. In J. A. Baun, & J. E. Dutton (Eds.), *Advances in Strategic Management* (pp. 63–88). UK: JAI Press.
- Elsbach, K. D. (1999). *An expanded model of organizational identification*. In R. I. Sutton & B. M. Staw (Eds.), *Research in Organizational Behavior* (Vol. 21, pp. 163–199). UK: Elsevier Science/JAI Press.
- Elsbach, K. D. & Bhattacharya, C. B. (2001). Defining who you are by what you're not: Organizational disidentification and the national rifle association. *Organization Science*, 12(4), 393–413.
- Fisher, R. & Wakefield, K. (1998). Factors leading to group identification: A field study of winners and losers. *Psychology and Marketing*, 15, 23–40.
- Flanagan, D., O'Shaughnessy, K. & Palmer, T. (2011). Re-assessing the relationship between the fortune reputation data and financial performance: Overwhelming influence or just a part of the puzzle?. *Corporate Reputation Review*, 14, 3–14.
- Fombrun, C. J. & Shanley, M. (1990). What's in a name? Reputation building and corporate strategy. *Academy of Management Journal*, 33(2), 233–258.
- Fombrun, C. J. (1996). *Reputation: Realizing value from corporate image*. Boston, MA.: Harvard Business School Press.
- Fombrun, C. J., Gardberg, N. A. & Sever, J. M. (2000). The reputation quotient: A multiple stakeholder measure of corporate reputation. *Journal of Brand Management*, 7(4), 241–255.
- Fornell, C. & Larcker, D. F. (1981). Evaluating structural equation models with unobservable variables and measurement error. *Journal of Marketing Research*, 18(1), 39–51.
- Fornell, C. & Cha, J. (1994). Partial least squares. In R. Bagozzi (ed.), *Advanced methods of marketing* (52–78). USA: Blackwell.

- Foroudi, M. M., Balmer, J. M., Chen, W., Foroudi, P. & Patsala, P. (2020). Explicating place identity attitudes, place architecture attitudes, and identification triad theory. *Journal of Business Research*, 109, 321-336.
- Fuller, J. B., Marler, L., Hester, K., Frey, L. & Relyea, C. (2006). Construed external image and organizational identification: A test of the moderating influence of need for self-esteem. *The Journal of Social Psychology*, 146(6), 701-716.
- Furman, D. M. (2010). The development of corporate image: A historiographic approach to a marketing concept. *Corporate Reputation Review*, 13(1), 63-75.
- Gioia, D. A. & Thomas, J. B. (1996). Identity, image, and issue interpretation: Sensemaking during strategic change in academia. *Administrative Science Quarterly*, 41(3), 370-403.
- Gioia, D. A., Schultz, M. & Corley, K. G. (2000). Organizational identity, image, and adaptive instability. *Academy of Management Review*, 25(1), 63-81.
- Gok, O. & Ozkaya, H. (2011). Does corporate reputation improve stock performance in an emerging economy? Evidence from Turkey. *Corporate Reputation Review*, 14(1), 53-61.
- Goker, I. E. K., Arar, T. & Uysal, B. (2017). The concept of corporate reputation and impacts on stock prices: Turkey Case. *The Journal of Accounting and Finance*, 74, 133-156.
- Gotsi, M. & Wilson, A. M. (2001). Corporate reputation: Seeking a definition. *Corporate Communications: An International Journal*, 6(1), 24-30.
- Graziano, A. & Raulin, M. (1997). *Research methods: A process of inquiry* (3rd. ed.). New York: Longman.
- Hair, J. F., Ringle, C. M. & Sarstedt, M. (2013). Partial least squares structural equation modeling: Rigorous applications, better results and higher acceptance. *Long Range Planning*, 46(1/2), 1-12.
- Hall, R. (1993). A framework linking intangible resources and capabilities to sustainable competitive advantage. *Strategic Management Journal*, 14(8), 607-618.
- Hansen, S. D., Dunford, B. B., Boss, A. D., Boss, R. W. & Angermeier, I. (2011). Corporate social responsibility and the benefits of employee trust: A cross-disciplinary perspective. *Journal of Business Ethics*, 102(1), 29-45.
- Harman, H. H. (1960). *Modern factor analysis*. Chicago, USA: University of Chicago Press.
- Haski-Leventhal, D., Roza, L. & Meijs, L. C. (2017). Congruence in corporate social responsibility: Connecting the identity and behavior of employers and employees. *Journal of Business Ethics*, 143(1), 35-51.
- Hatch, M. J. & Schultz, M. (1997). Relations between organizational culture, identity and image. *European Journal of Marketing*, 31(5/6), 356-365.
- Hatch, M. J. & Schultz, M. S. (2000). Scaling the Tower of Babel: Relational differences between identity, image and culture in organizations. In M. Schultz, M. J. Hatch & M. H. Larsen, (Eds.), *The expressive organization: Linking identity, reputation, and the corporate brand* (pp. 13-35). Oxford University Press,
- Hatch, M. J. & Schultz, M. (2001). Are the strategic stars aligned for your corporate brand?. *Harvard Business Review*, February, 79(2), 128-34.
- Helm, S. (2007). The role of corporate reputation in determining investor satisfaction and loyalty. *Corporate Reputation Review*, 10(1), 22-37.
- Horn, P. & Griffeth, R. (1995). *Employee turnover*. Cincinnati, OH: South-Western.

- Howell, J. M. & Avolio, B. J. (1993). Transformational leadership, transactional leadership, locus of control, and support for innovation: Key predictor of consolidated business-unit performance. *Journal of Applied Psychology*, 78(6), 891-902.
- Hurley, R. F. & Hult, G. T. M. (1998). Innovation, market orientation, and organizational learning: An integration and empirical examination. *Journal of Marketing*, 62(3), 42-54.
- Inglis, R., Morley, C. & Sammut, P. (2006). Corporate reputation and organisational performance: An Australian study. *Managerial Auditing Journal*, 21(9), 934-947.
- Karimi J. (2009). Emotional labor and psychological distress: Testing the mediatory role of work family conflict. *European Journal Of Social Sciences*, 11(4), 584-598.
- Keh, H. T. & Xie, Y. (2009). Corporate reputation and customer behavioral intentions: The roles of trust, identification and commitment. *Industrial Marketing Management*, 38(7), 732-742.
- Ketokivi, M. A. & Schroeder, R. G. (2004). Perceptual measures of performance: Fact or fiction?. *Journal of Operations Management*, 22(3), 247-264.
- Kim, J. N. & Rhee, Y. (2011). Strategic thinking about employee communication behavior (ECB) in public relations: Testing the models of megaphoning and scouting effects in Korea. *Journal of Public Relations Research*, 23(3), 243-268.
- Kleijnen, M., De Ruyter, K., & Wetzels, M. (2007). An assessment of value creation in mobile service delivery and the moderating role of time consciousness. *Journal of Retailing*, 83(1), 33-46.
- Kock, N. (2015). Common method bias in PLS-SEM: A full collinearity assessment approach. *International Journal of e-Collaboration*, 11, 1-10.
- Koporcic, N. & Halinen, A. (2018). Interactive network branding: Creating corporate identity and reputation through interpersonal interaction. *IMP Journal*, 12(2), 392-408.
- Kreiner, G. E. & Ashforth, B. E. (2004). Evidence toward an expanded model of organizational identification. *Journal of Organizational Behavior*, 25(1), 1-27.
- Lee, E. S., Park, T. Y. & Koo, B. (2015). Identifying organizational identification as a basis for attitudes and behaviors: A meta-analytic review. *Psychological Bulletin*, 141(5), 1049-1080.
- Lee, J. & Roh, J. J. (2012). Revisiting corporate reputation and firm performance link. *Benchmarking: An International Journal*, 19(4), 649 – 664.
- Lei, Q. (2011). Financial value of eputation: Evidence from the ebay auctions of gmail invitations. *The Journal of Industrial Economics*, 59(3), 422-456.
- Mael, F., & Ashforth, B. E. (1992). Alumni and their Alma Mater: A partial test of the reformulated model of organizational identification. *Journal of Organizational Behavior*, 13(2), 103-123.
- Maurya, U. K., Mishra, P., Anand, S. & Kumar, N. (2015). Corporate identity, customer orientation and performance of SMEs: Exploring the linkages. *IIMB Management Review*, 27(3), 159-174.
- Melewar, T. C. (2003). Determinants of the corporate identity construct: A review of the literature. *Journal of Marketing Communications*, 9(4), 195-220.
- Men, L. R. (2012). CEO credibility, perceived organizational reputation, and employee engagement. *Public Relations Review*, 38(1), 171-173.

- Microsoft in Financial Services (December 7, 2017). The top five things a customer needs from their bank. <https://cloudblogs.microsoft.com/industry-blog/financial-services/2017/12/07/the-top-five-things-a-customer-needs-from-their-bank/>
- Mignonac, K., Herrbach, O. & Guerrero, S. (2006). The interactive effects of perceived external prestige and need for organizational identification on turnover intentions. *Journal of Vocational Behavior*, 69(3), 477-493.
- Munawir, M., Raharjo, K., Djalil, M.A., Syahputra, H., Muslim, B. & Adam, M. (2019). Dimensions of identity strength and Organizational Citizenship Behavior (OCB) in establishing good university governance and performance of religious ideology-based higher educations. *Journal of Applied Research in Higher Education*, 11(2), 250-272.
- Neville, B. A., Bell, S. J. & Mengüç, B. (2005). Corporate reputation, stakeholders and the social performance-financial performance relationship. *European Journal of Marketing*, 39(9/10), 1184-1198.
- Nguyen, N. & Leblanc, G. (2001). Corporate image and corporate reputation in customers' retention decisions in services. *Journal of Retailing and Consumer Services*, 8(4), 227-236.
- Nguyen, N. T. T., Nguyen, N. P. & Hoai, T. T. (2021). Ethical leadership, corporate social responsibility, firm reputation, and firm performance: A serial mediation model, *Heliyon*, 7(4), e06809, 1-9.
- Olins, W. (1995). *The new guide to corporate identity*. Gower, Aldershot: Design Council.
- Oncer, A. Z. & Yildiz, M. G. (2012). The impact of ethical climate on relationship between corporate reputation and organizational identification. *Procedia – Social and Behavioral Sciences*, 58, 714-723.
- Park, J., Lee, H. & Kim, C. (2014). Corporate social responsibilities, consumer trust and corporate reputation: South Korean consumers' perspectives. *Journal of Business Research*, 67(3), 295-302.
- Powell, T. C. (1992). Research notes and communications strategic planning as competitive advantage. *Strategic Management Journal*, 13(7), 551-558.
- Pratt M.G. (1998). To be or not to be: Central questions in organizational identification, In D.A. Whetten & P.C. Godfrey (Eds.), *Identity in organizations: Building theory through conversations* (pp. 171-207). Thousand Oaks, CA: Sage Publications.
- Pratt, M. G. (2000). The good, the bad, and the ambivalent: Managing identification among amway distributors. *Administrative Science Quarterly*, 45(3), 456-493.
- Pham, H. S. T & Tran, H. T. (2020). CSR disclosure and firm performance: The mediating role of corporate reputation and moderating role of CEO integrity. *Journal of Business Research*, 120, 127-136.
- Podnar, K. & Golob, U. (2015). The twin foci of organizational identification and their relevance for commitment: A study of the marketing communications industry. *Journal of Business Economics and Management*, 16(1), 214-227.
- Radomir, L., Plaias, I. & Nistor, V. C. (2014). Corporate reputation, image and identity: conceptual approaches. *International Conference "Marketing – From Information To Decision"*, Romania, 7th Edition, 219-229.
- Rahayu, S. M. (2019). Mediation effects financial performance toward influences of corporate growth and assets utilization. *International Journal of Productivity and Performance Management*, 68(5), 981-996.

- Richard, O. C., Wu, P. & Chadwick, K. (2009). The impact of entrepreneurial orientation on firm performance: The role of CEO position tenure and industry tenure. *The International Journal of Human Resource Management*, 20(5), 1078-1095.
- Riketta, M. (2005). Organizational identification: A meta-analysis. *Journal of Vocational Behavior*, 66(2), 358-384.
- Ringle, C., Wende, S. & Will, A. (2005). SmartPLS 2.0 (Beta) (www.smartpls.de).
- Roberts, P. W. & Dowling, G. R. (2002). Corporate reputation and sustained superior financial performance. *Strategic Management Journal*, 23(12), 1077-1093.
- Rose, C. & Thomsen, S. (2004). The impact of corporate reputation on performance: Some Danish evidence. *European Management Journal*, 22(2), 201-210.
- Rowe, W. G. & Morrow Jr, J. L. (1999). A note on the dimensionality of the firm financial performance construct using accounting, market, and subjective measures. *Canadian Journal of Administrative Sciences*, 16(1), 58-71.
- Sanchez, J. L. F. & Sotorrio, L. L. (2007). The creation of value through corporate reputation. *Journal of Business Ethics*, 76(3), 335-346.
- Santos, J. B. & Brito, L. A. L. (2012). Toward a subjective measurement model for firm performance. *BAR-Brazilian Administration Review*, 9(SPE), 95-117.
- Scheepers, D. & Ellemers, N. (2019). Social identity theory. In K. Sassenberg & M. L.W. Vliek (Eds), *Social psychology in action Evidence-Based Interventions from Theory to Practice* (pp. 129-143). Springer.
- Shamma, H. M. & Hassan, S. S. (2009). Customer and non-customer perspectives for examining corporate reputation. *Journal of Product & Brand Management*, 18(5), 326-337.
- Siano, A., Vollero, A. & Siglioccolo, M. (2007). Corporate reputation management: A set of drivers in the governance-structure-system model. Empirical evidences from crisis communication. *11th International Conference on Reputation, Brand, Identity & Competitiveness*, BI Norwegian School of Management, Oslo, Norway, May 31 – June 3.
- Smidts, A., Pruyn, A. T. H. & Van Riel, C. B. (2001). The impact of employee communication and perceived external prestige on organizational identification. *Academy of Management Journal*, 44(5), 1051-1062.
- Stanske, S. (2017). Organizational identity and its applications: A direction for further research – Properties of growth, contextual identities and micro-level processes – In C. Dörrenbächer, M. Tomenendal & S. Stanske (Eds.), *Organizational identity and firm growth* (pp. 13-62). London, UK: Palgrave Macmillan Books.
- Sumer, G. (2013). *According to Turkish tax system duties and obligations of banks* (Unpublished doctoral thesis). University of Bursa Uludağ, Institute of Social Sciences, Bursa.
- Sumer, G. (2016). Historical development of the Turkish banking sector and banking sector in comparison with EU. *Gazi University Journal of Faculty of Economics and Administrative Sciences*, 18(2), 485-508.
- Svensson, L. E. O. (2006). Social value of public Information: Comment: Morris and Shin (2002) is actually pro-transparency, not con. *The American Economic Review*, 96(1), 448-452.
- Tajfel, H. (1979). Individuals and groups in social psychology. *British Journal of Social & Clinical Psychology*, 18(2), 183-190.

- Tajfel, H. & Turner, J. C. (1986) The social identity theory of intergroup behavior. In S. Worchel & W. G. Austin (Eds.), *Psychology of intergroup relation* (pp. 7-24). Chicago, USA: Hall Publishers.
- Tracey, N. P. (2014). *Corporate reputation and financial performance: Underlying dimensions of Corporate reputation and their relation to sustained financial performance* (Unpublished doctoral thesis). Queensland University of Technology, Australia.
- Venkatraman, N. & Ramanujam, V. (1986). Measurement of business performance in strategy research: A comparison of approaches. *Academy of Management Review*, 11(4), 801-814.
- Venkatraman, N. & Ramanujam, V. (1987). Measurement of business economic performance: an examination of method convergence. *Journal of Management*, 13(1), 109-122.
- Vidaver-Cohen, Deborah. (2007). Reputation beyond the rankings: A conceptual framework for business school research. *Corporate Reputation Review*, 10, 278-304.
- Voss, Z. G., Cable, D. M. & Voss, G. B. (2006). Organizational identity and firm performance: What happens when leaders disagree about “Who we are?”. *Organization Science*, 17(6), 741-755.
- Walker, K., (2010). A systematic review of the corporate reputation literature: Definition, measurement, and theory. *Corporate Reputation Review*, 12, 357-387.
- Wall, T. D., Michie, J., Patterson, M., Wood, S. J., Sheehan, M., Clegg, C. W. & West, M. (2004). On the validity of subjective measures of company performance. *Personnel Psychology*, 57(1), 95-118.
- Warrad, L., & Al Omari, R. (2015). The impact of turnover ratios on jordanian services sectors’ performance. *Journal of Modern Accounting and Auditing*, 11(2), 77-85.
- Willets, G. & Clarke, D. (2014). Constructing nurses’ professional identity through social identity theory. *International Journal of Nursing Practice*. 20, 164-169.
- Witting, M. (2006). Relations between organizational identity, identification and organizational objectives: An empirical study in municipalities (Unpublished master’s thesis). University of Twente.
- Zehir, C., Gurolb, Y., Karabogac, T. & Koled, M. (2016). Strategic human resource management and firm performance: The mediating role of entrepreneurial orientation. *Procedia – Social and Behavioural Sciences*, 235, 372-381.

APPENDIX

Appendix Measure

Standardized loadings are in parentheses.

α : Cronbach alpha, CR: composite reliability; AVE: average variance extracted; r_{wg} : inter-rater agreement

* denotes the dropped item; either they reduce the AVE to less than .50, or they have low loading weights.

Organization Identity Strength (adapted from Kreiner&Ashforth, 2004 and Gioia&Thomas, 1996)

There is a common sense of purpose in this organization (.734)

This organization has a clear and unique vision (.740)

There is a strong feeling of unity in this organization *

This organization has a specific mission shared by its employees (.697)

Corporation's managers have a sense of pride in the corporation's goals and missions. (.778)

Corporation's managers feel the corporation has carved out a significant place in banking and finance sector. (.817)

Corporation's managers well defined set of goals and objectives for the corporation. (.717)

Corporation's managers are adopted the corporation's history and traditions. (.649)

Corporation's managers and employees identify strongly with the corporation (.605)

$\alpha=.87$

CR=.90

AVE=.52

$r_{wg}=.76$

Identification (adapted from Kreiner&Ashforth, 2004)

When someone criticizes my organization, it feels like a personal insult (.980)

I am very interested in what others think about my organization (.925)

When I talk about this organization, I usually say 'we' rather than 'they' (.981)

This organization's successes are my successes (.919)

When someone praises this organization it feels like a personal compliment (.873)

If a story in the media criticized this organization, I would feel embarrassed *

$\alpha=.97$

CR=.96

AVE=.84

r_{wg} =.85

Disidentification (adapted from Kreiner&Ashforth, 2004)

I am embarrassed to be part of this organization *

This organization does shameful things *

I have tried to keep the organization I work for a secret from people I meet
(.982)

I want people to know that I disagree with how this organization behaves
(.972)

I have been ashamed of what goes on in this organization (.981)

α =.98

CR=.99

AVE=.96

r_{wg} =.88

CoR (adapted from Fombrun et al., 2000)

Emotional Appeal

I have a good feeling about the company (.911)

I admire and respect the company (.822)

I trust this company (.762)

α =.78

CR=.87

AVE=.70

r_{wg} =.69

Products and Services

Stands behind its products and services (.797)

Develops innovative products and services (.898)

Offers high quality products and services (.818)

Offers high priced products and services *

$$\alpha=.76$$

$$CR=.85$$

$$AVE=.59$$

$$r_{wg}=.75$$

Vision and Leadership

Has excellent leadership (.830)

Has a clear vision for its future (.858)

Recognizes and takes advantages of market opportunities (.768)

$$\alpha=.76$$

$$CR=.86$$

$$AVE=.67$$

$$r_{wg}=.80$$

Financial Appeal

This company can be counted on to perform well financially (.903)

This company has a proven track record.*

This company has good long-term prospects (.646)

This company makes good use of its corporate assets (.711)

$$\alpha=.65$$

$$CR=.80$$

$$AVE=.58$$

$$r_{wg}=.65$$

Social and Environmental Responsibility

Is an environmentally responsible company (.941)

Maintains high standards in the way it treats people. (.941)

Reduces its profits to ensure a clean environment *

$$\alpha=.87$$

$$CR=.94$$

$$AVE=.89$$

$$r_{wg}=.82$$

Financial Performance (adapted from Zehir et al., 2016)

Sales growth (.709)

Market share (.856)

Return on investment (.745)

General Profit (836)

$\alpha=.80$

CR=.87

AVE=.62

$r_{wg}=.83$